

FREESTANDING SPEAKERS

IMPRESSION SERIES



EMP
Tek

OWNER'S MANUAL

Introduction

Congratulations on your purchase of Impression Series freestanding speakers! Your speakers are the result of many years of research and development dedicated to producing high quality products for home audio and audio/video systems.

This manual contains features, setup recommendations and specifications for the Impression Series freestanding speakers. It is recommended you thoroughly read through the material contained in this manual before connecting your speakers. This will ensure you have a good understanding of how to setup your speakers for optimum performance and allow for years of listening enjoyment.

Impression Series Speakers

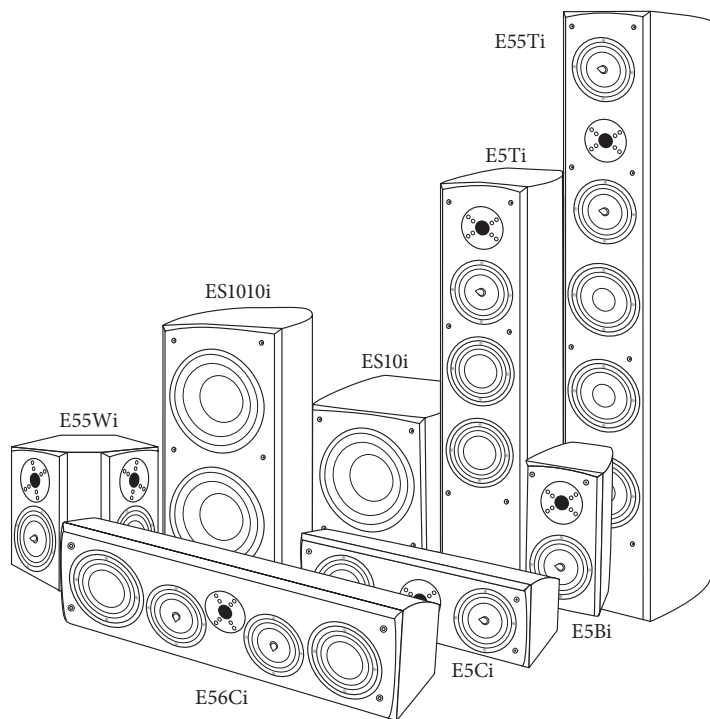

Break-in Period

Allow several hours of listening time to adequately break-in the Impression Series speakers. As the speakers break-in, the driver suspensions will loosen. The result of break-in will be an increase in low frequency response, improved definition, and increased clarity and detail.

Care and Cleaning

To maintain speaker appearance, we recommend wiping them down with a clean damp soft cloth. To clean dust from the grille cloth, use a vacuum with a brush attachment.

Features

The Impression Series speakers feature poly-matrix cone bass drivers and aluminized poly-matrix cone midrange drivers. These rigid cones resist flexing and contribute to the accurate reproduction of the audio signal, providing higher overall sound quality.

A quality fabric dome tweeter is used for high frequencies in Impression Series speakers. Higher power handling is achieved through the use of magnetic liquid cooling in the tweeter. To protect the tweeter against being over driven, a polyswitch (a current limiting device) is incorporated in the crossover network.

Each Impression Series speaker model features a crossover network to minimize driver interaction irregularities and maximize the ability of each driver to accurately reproduce its respective band of frequencies. Five-way binding posts ensure a solid electrical connection to these crossover networks.

The Impression Series speakers' cabinets are constructed of ½-inch medium density fiberboard because of its inert properties, thereby minimizing sound coloration. The front baffles are double layered to 1-inch thickness helping to prevent excess acoustic radiation from the cabinet.

Attaching Speaker Wires

If using a banana jack, attach the matching positive or negative wire and push directly into binding post top hole.

If not using a banana jack, simply loosen the binding nut to allow the hole in the side of the terminal to become exposed. Strip ¼-inch of the insulation from the end of the speaker wire and insert the exposed wire end into the now exposed hole in the side of the terminal. Tighten the binding nut by turning the nut clockwise until the speaker wire is secured. Repeat for the other speaker wire(s) as necessary.

Using a Banana Jack

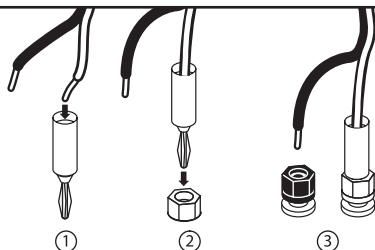

Without Banana Jack

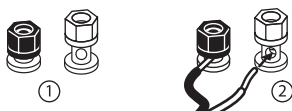

Room Setup Suggestions

In order to obtain the best possible sound from your speaker system, it is important to determine where the speakers will sound best in your listening room. Room reflections from the floor, ceiling and side walls influence the balance, imaging and overall sonic quality at the listening position. Experiment with speaker placement to determine which location offers the best overall sound. As a general guide, use the room layout diagram and the following descriptions when setting up a home theater system. Some speakers shown in the diagram may not always be applicable to your system.

Front Main Speakers

As a starting point, place your left and right tower speakers at least 15 inches from the wall and 7-feet apart from each other. The distance from the listening position to each speaker should be close to the distance that separates the two main speakers. Angling the speakers inward towards the listening position may give a more spacious and realistic sound stage.

Center Channel Speaker

The center channel speaker should be placed in the center between both left and right main speakers. Often this positioning dictates placing the speaker either directly above or below a television monitor.

Rear Surround Speakers

The 2-way bookshelf speakers may be placed either above, behind or to the sides of the listening position. The listening position should be centered between the surround speakers. For best performance you may want to experiment with angling the surround speakers either towards or away from the listening position. If using E55Wi surround speakers, the optimal location for these is about 5-6 feet high on the walls to the left and right of the listening position. This position should allow one half of the speaker to point forward of the listening position, while the other half of the speaker points behind the listening position.

Subwoofer

In order to obtain the best possible sound from your subwoofer, it is important to determine where the subwoofer will sound best in your listening room. Sound reflections from the floor, ceiling and side walls influence the balance, imaging and overall sonic quality at the listening position. Experiment with subwoofer placement to determine which location offers the best overall sound.

Placement of the subwoofer will largely determine quality, quantity and extension of the bass frequencies within your listening room. Bass frequencies are reinforced by close room boundaries. Placing the subwoofer close to a corner will make the subwoofer sound louder and boost the very lowest frequencies.

Placing the subwoofer away from walls will provide the least reinforcement, making the bass sound subjectively thinner than if the woofer were closer to a wall. Good results can usually be obtained by placing a subwoofer along a wall 1-3 feet from a corner. Experiment with placement of the subwoofer and the sub-amplifier controls to achieve the proper bass balance.

Room Setup Suggestions (continued)

IMPORTANT NOTICE REGARDING BASS MANAGEMENT: It is important the signal being sent to the subwoofer be a non-boosted or “flat” signal. To be sure of this, check the settings on your receiver or processor to make sure any “bass boost”, “super bass” or “loudness” is set to Off. In most cases a home theater receiver or processor will determine the crossover frequency through bass management settings. In this configuration, connect the receiver’s or processor’s subwoofer output to the subwoofer’s LFE Line Level Input. Your subwoofer will now reproduce the bass frequencies the way they were originally recorded. Use the subwoofer level control and the individual bass management control within the receiver or processor to adjust the subwoofers’ volume if necessary. Once set, the volume controls should not need to be altered as the subwoofers’ volume will track with the master volume control of your receiver or processor.

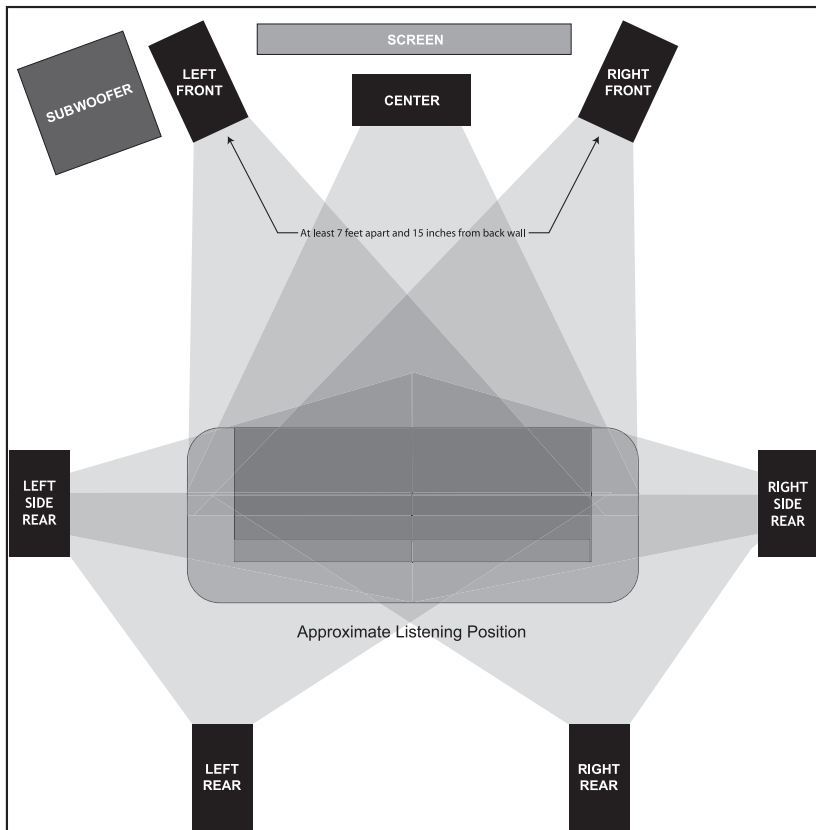

NOTE: There are several different surround formats available. Dolby Pro-Logic, Pro-Logic II, Dolby Digital and DTS generally have a 5 speaker plus subwoofer requirement. Dolby Digital EX and DTS ES add a center rear speaker. Dolby TrueHD and DTS Master Audio available only on Blu-ray disc, generally have a 7.1 requirement. Please consult your audio/video professional to determine which system is best for you and how many speakers you will require.

Subwoofer Safety Instructions



The lightning flash with the arrowhead symbol within an equilateral triangle, is intended to alert the user to the presence of un-insulated “dangerous voltage” within the product enclosure that may be of sufficient magnitude to constitute a risk of shock to persons.



The exclamation point within an equilateral triangle is intended to alert the user to the presence of important operating and maintenance (servicing) instructions in the literature accompanying the product.

When using your subwoofer, basic safety precautions should always be followed to reduce the risk of fire, electric shock, and injury.

1. Read and understand all instructions in this users manual before operating the subwoofer and retain this user manual for future reference.
2. Follow all warnings and instructions in this manual and any marked on the back of the Subwoofer.
3. Never touch the woofer or push objects of any kind into the woofer.
4. The subwoofer should be connected to a power supply compatible with the power consumption requirements, see the specifications section of this manual.
5. If mounting the subwoofer on a stand, the wall, or other device only do so as recommended by an authorized technician.
6. Place the subwoofer a safe distance from all heat sources such as radiators, stoves, or heaters.
7. Do not operate the subwoofer near water—for example, near a bathtub, kitchen sink or in a wet basement; or a swimming pool.
8. Power supply cords should be routed so they are not likely to be walked on or pinched by items placed upon or against them.
9. Any service or repair required must be performed by qualified, authorized technician.

Subwoofer Amplifier Controls and Setup

This section describes the functions and/or use for each of the amplifier controls located on the back of the subwoofer. See the diagram of the back of the subwoofer on the next page.

1. **Voltage Selector Switch:** Before connecting the amplifier to any power source make sure the AC Voltage Selector is set to either 110V or 220V to match the power voltage in your area.

WARNING! If the voltage setting does not match the AC power supplied, damage to the Subwoofer Amplifier may result.

2. **Volume/Gain Control:** The volume/level control should be at the minimum setting (all the way counter-clockwise) before plugging the subwoofer into an AC wall socket. Once plugged in, turn the level control up one quarter of a turn (9 o'clock position) for an initial setting. The level control may be adjusted while playing to match the subwoofer level with the rest of the system.

IMPORTANT! The volume control should be at the minimum setting (all the way counter-clockwise) before plugging the subwoofer into an AC wall socket.

3. **Crossover Frequency Control:** The variable crossover frequency control allows you to set the low-pass crossover point of the subwoofer anywhere from 40-150 Hz. Increasing the crossover frequency will allow more mid-bass output from the subwoofer. Decreasing the frequency will allow only deeper bass from the subwoofer. Experiment with setting the crossover frequency control at highest setting initially.

NOTE: Read the Important Notice regarding bass management on page 4.

4. **Auto Signal Tracking:** The subwoofer amplifier uses “smart” signal tracking circuitry. Once the power cord is plugged in and the switch set to auto, the amplifier automatically turns on when a signal is detected at the preamplifier or high level inputs and turns off when no signal has been detected for about 15 minutes.
5. **Phase Control:** This control changes the phase of the subwoofer. Changing the phase will change the way the subwoofer and main speakers interact with each other at the crossover frequency. Varying the phase position may result in more or less mid bass depending on the phasing between the main speakers and the subwoofer. Generally, the phase is left at the 0 degrees position.
6. **Line Inputs:** Line level inputs are used to connect to most full-range stereo receivers or processors, use both the L and R terminals.
7. **LFE In:** The Low Frequency Effect input is to connect to the “LFE” bass management output of the receiver or processor and may also be called “Subwoofer Output”.
8. **LFE Out:** This RCA terminal is for “daisy chaining” to another powered subwoofer.

Subwoofer Amplifier Controls and Setup (continued)

9. **Fuse Access:** This is the power fuse access.

WARNING! In the event the fuse must be replaced, the replacement fuse must match exactly the original fuse value. If the replacement fuse is not of the same value, damage to the Subwoofer Amplifier may result.

CAUTION! Before replacing the fuse, disconnect the power cord from the power receptacle.

10. **Power:** Power on and off switch.

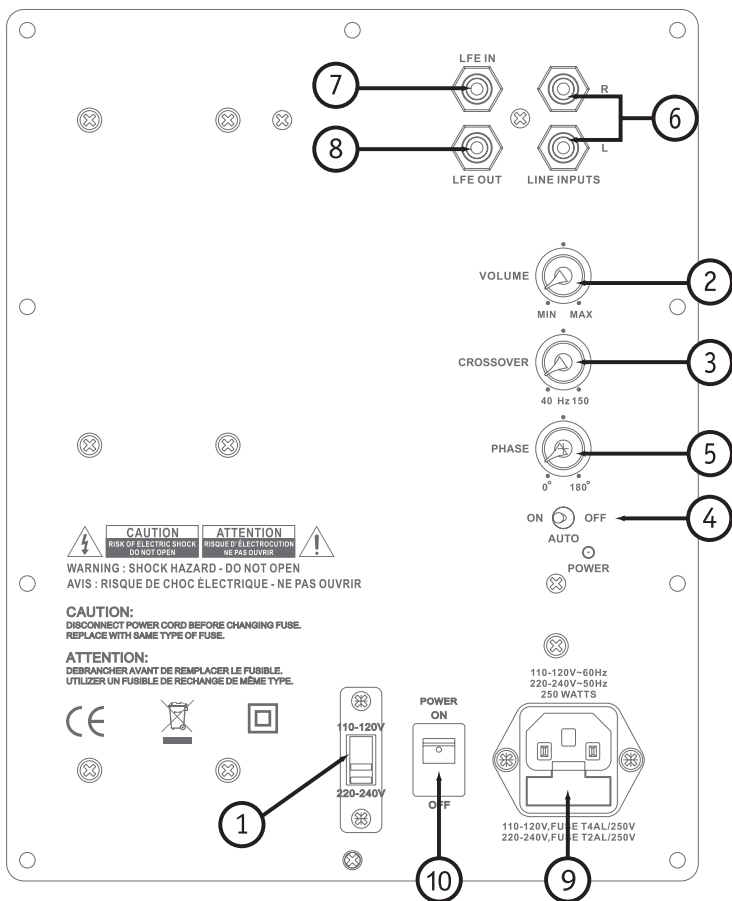

2011 + Impression Series Subwoofer Diagram.

Tower Speaker Outrigger Installation

Use these attractive, tower speaker outriggers for the Impression Series tower speakers to create a wider support base for the cabinet. These outriggers make your tower speakers more stable, and are ideal when placing them on a thickly carpeted floor.

Package contents include:

- 1 each small outriggers for back of cabinet
- 1 each large outriggers for front of cabinet
- 4 metal spike feet
- 4 metal rubber cone feet
- 4 each top cap nuts
- 4 each threaded adjustment washers
- 4 each machine screws

The metal spike feet work best on carpeted surfaces. The rubber cone feet have been included for use with wooden or tiled floors.

Attach the tower speaker outrigger plates to the bottom of the speaker with the machine screws provided, as shown in figure 2 below. The larger plate should be at the front of the speaker and the smaller plate at the back of the speaker.

NOTE: To prevent scratching or damaging of the cabinet, turn the tower upside down on a soft surface when attaching the outrigger feet.

Attach the metal spike or rubber cone feet using the top cap nuts as shown in figure 1. Adjust the level/height using the adjustment washer above the metal spike or rubber cone feet.

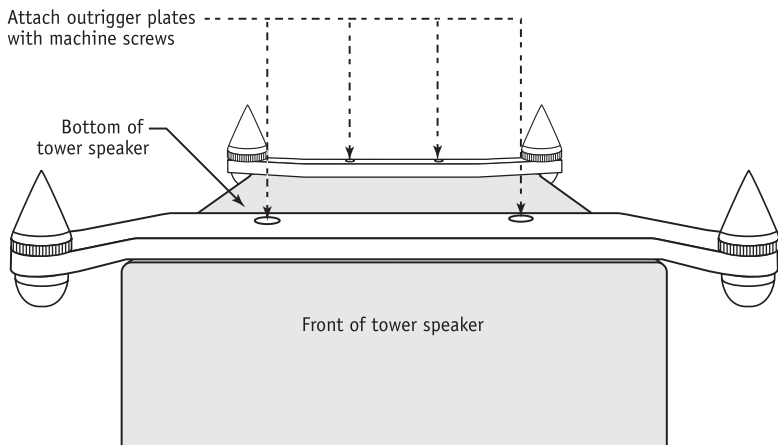
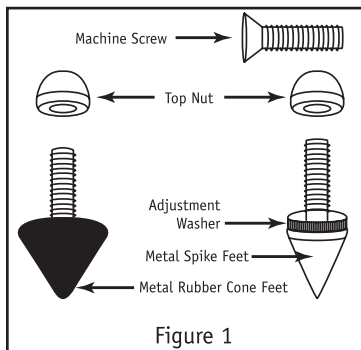

Figure 2

Specifications

Model	E55Ti Tower	E5Ti Tower	E5Ci Center Channel
Frequency Response:	40Hz – 20kHz	50Hz – 20kHz	60Hz – 20kHz
Sensitivity:	88dB	87dB	87dB
Recommended Power:	50-200 Watts	50-150 Watts	50-120 Watts
Woofers:	(3) 6½" (165mm) Polypropylene (2) 5¼" (133mm) Aluminized Poly-matrix	(2) 6½" (165mm) Polypropylene (1) 5¼" (133mm) Aluminized Poly-matrix	(2) 5¼" (133mm) Aluminized Poly-matrix
Tweeter:	(1) 1" (25mm) Fabric Dome	(1) 1" (25mm) Fabric Dome	(1) 1" (25mm) Fabric Dome
Impedance:	6 Ohms	6 Ohms	6 Ohms
Crossover Frequencies:	120Hz / 3000 Hz	120Hz / 3000 Hz	3000 Hz
Dimensions:	8½" (216mm) W 47½" (1207mm) H 12¼" (311mm) D	8½" (216mm) W 35½" (902mm) H 12¼" (311mm) D	21¾" (553mm) W 7¼" (184mm) H 7¼" (197mm) D
Cabinet:	High-gloss Red Burl or High-gloss Black Ash	High-gloss Red Burl or High-gloss Black Ash	High-gloss Red Burl or High-gloss Black Ash
Weight:	52 lbs. (23.59 Kg)	35 lbs. (15.88 Kg)	11.5 lbs. (5.22 Kg)

Specifications (continued)

Model	E5Bi Bookshelf	ES10i Subwoofer	ES1010i Subwoofer
Frequency Response:	60Hz – 20kHz	35Hz – 180Hz	30Hz – 180Hz
Sensitivity:	85dB	N/A	N/A
Recommended Power:	50-100 Watts	250 Watts RMS (Amplifier Power)	250 Watts RMS (Amplifier Power)
Woofers:	(1) 5¼" (133mm) Aluminized Poly-matrix	(1) 10" (254mm) Poly-matrix Cone	(2) 10" (254mm) Poly-matrix Cone
Tweeter:	(1) 1" (25mm) Fabric Dome	N/A	N/A
Impedance:	8 Ohms	N/A	N/A
Crossover Frequencies:	3000 Hz	40Hz – 150Hz	40Hz – 150Hz
Dimensions: (Includes Base)	6⅞" (175mm) W 12¾" (324mm) H 8" (203mm) D	14⅞" (359mm) W 15" (381mm) H 16¼" (413mm) D	13" (330mm) W 27½" (699mm) H 19" (483mm) D
Cabinet:	High-gloss Red Burl or High-gloss Black Ash	High-gloss Red Burl or High-gloss Black Ash	High-gloss Red Burl or High-gloss Black Ash
Weight:	7.5 lbs. (3.40 Kg)	27 lbs. (12.25 Kg)	45 lbs. (20.41 Kg)

Specifications (continued)

Model	E55Wi Surround On-wall	E56Ci Large Center	
Frequency Response:	65Hz – 20kHz	50Hz – 20kHz	
Sensitivity:	87dB	87dB	
Recommended Power:	50-130 Watts	50-175 Watts	
Woofers(s):	(2) 5¼" (133mm) Aluminized Poly-matrix	(2) 6½" (254mm) Polypropylene (2) 5¼" (133mm) Aluminized Poly-matrix	
Tweeter(s):	(2) 1" (25mm) Fabric Dome	(1) 1" (25mm) Fabric Dome	
Impedance:	6 Ohms	6 Ohms	
Crossover Frequencies:	3,000 Hz	600 Hz, 3,000 Hz	
Dimensions: (Includes Base)	11½" (292mm) W 12" (301mm) H 6" (152mm) D	31" (787mm) W 8½" (216mm) H 10½" (267mm) D	
Cabinet:	High-gloss Red Burl or High-gloss Black Ash	High-gloss Red Burl or High-gloss Black Ash	
Weight:	12 lbs. (5.44 Kg)	28 lbs. (12.70 Kg)	

Troubleshooting—Speakers

Situation:	Probable Cause:	Solution:
No sound from speakers.	Speaker wire not connected.	Make sure wire is connected at both the speaker and the amplifier observing proper polarity.
No sound from one speaker.	Speaker selector on amplifier is not on.	Activate proper selector on amplifier.
	Balance control on receiver or pre-amp is not centered.	Place balance control in the center.
	Speaker wire not securely connected.	Check all connections at amplifier and speakers.
Very little bass and/or imaging.	Speakers are wired out of phase.	Check entire system for proper polarity and make adjustments as necessary.

Troubleshooting—Subwoofer

Situation:	Probable Cause:	Solution:
No sound from subwoofer.	Amplifier is not connected to constant power outlet.	Make certain the amplifier is plugged into an unswitched AC power outlet.
	Amplifier is not receiving an audio signal from receiver or processor.	Make certain there is an audio signal from receiver or processor.
	Amplifier fuse might be blown.	Replace fuse (if fuse is not readily accessible, consult with EMP Tek for more information).
Performance is less than expected.	Crossover frequency is not adjusted correctly.	Adjust the crossover frequency by turning the crossover frequency control clockwise until the desired sound is obtained.

Warranty

Engineered Music Products "EMP Tek" warrants the Impression Series speakers (the "Product") to be free from original manufacturing defects in materials and workmanship for five (5) years, with subwoofer amplifiers covered for one (1) year from the original date of purchase from an authorized EMP Tek dealer. This warranty extends only to the original consumer purchaser. EMP Tek does not warrant goods used in industrial applications. This warranty does not cover any expenses incurred in any removal or re-installation of the product.

If the product should prove defective within the warranty period, contact EMP Tek for a return authorization number prior to returning the product. Once the return authorization number has been obtained ship the product back to EMP Tek, along with the original sales invoice or other proof of purchase, which establishes eligibility for warranty service and the return authorization number clearly marked of the outside of the package, see www.emptek.com for detailed information on returns. EMP Tek will, at its option, replace or repair the product free of charge and return the product by prepaid delivery. This warranty does not apply to any product which has been damaged, misused, altered, neglected or repaired by anyone other than an EMP Tek authorized service facility.

Any implied warranties including fitness for use and merchantability are limited in duration to the period of the express warranties set forth above, and no person is authorized to assume for EMP Tek any other liability in connection with the sale of the product. EMP Tek expressly disclaims liability for any incidental and consequential damages caused by the product or the result of failure of this product. The remedies provided under this warranty are exclusive and in lieu of all others.

This warranty gives specific legal rights. In addition, there may be other legal rights arising from the sale of the product, which vary from state to state. Some states do not allow the exclusion or limitation of incidental or consequential damages, so the above limitation or exclusion may not apply in some areas.



382 Marshall Way, Layton, Utah • USA • 84041
Phone: (801) 991-1308 • Fax: (801) 543-3300
www.emptek.com